

WANNER

HYDRA-CELL PRO[®]

SEAL-LESS PUMP TECHNOLOGIES

Models

D10

G10

Serial Number
498105 and Above

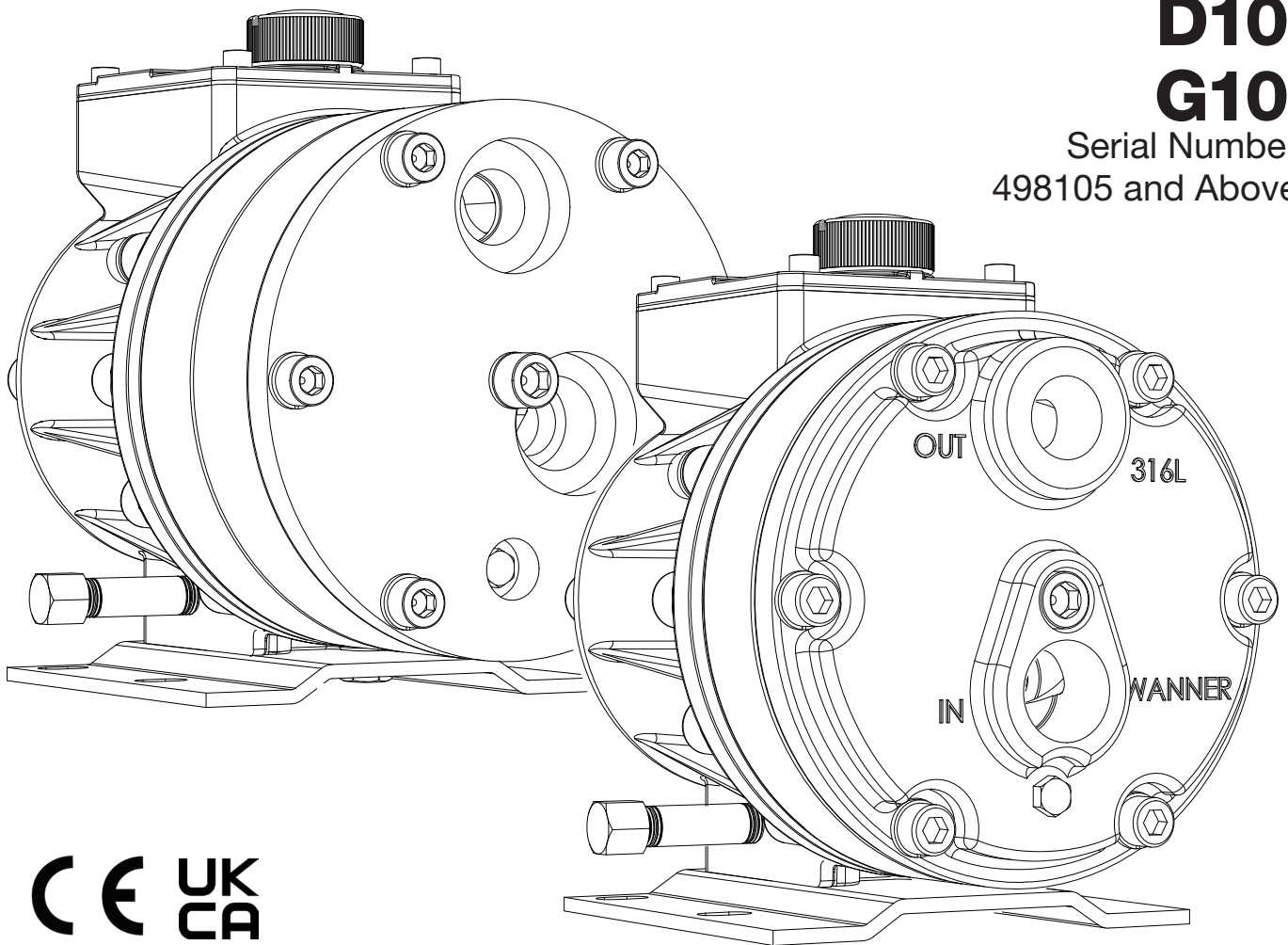

WANNER[®]

D/G10 Contents

	Page
Specifications.....	2
Dimensions	4
Installation.....	5
Maintenance.....	11
Fluid End Service.....	12
Hydraulic End Service.....	15
Fluid End Parts.....	18
Hydraulic End Parts	21
Troubleshooting.....	23
Pump Motor Adapter Kits.....	24
Wanner Tool Kit.....	25
Replacement Parts Kits	26
Warranty.....	27

D/G10 Specifications

Maximum Flow Rate	8.8 gpm (33.4 l/min)
Maximum Pressure	Metallic: 1500 psi (103 bar) Non-Metallic: 350 psi (24 bar)

Flow Capacities @ 1000 psi (69 bar)			
Model	rpm	gpm	l/min
D/G10-X	1450	8.1	30.6
D/G10-E	1750	8.8	33.4

Flow Capacities @ 1500 psi (103 bar)			
Model	rpm	gpm	l/min
D/G10-X	790	4.26	15.1
D/G10-E	790	3.87	14.7

Delivery @ 1500 psi (103 bar)		
Model	gal/rev	liters/rev
D/G10-X	0.0054	0.0205
D/G10-E	0.0049	0.0186

Delivery @ 1000 psi (69 bar)		
Model	gal/rev	liters/rev
D/G10-X	0.0056	0.0211
D/G10-E	0.0051	0.0191

Maximum Discharge Pressure	
Metallic Heads:	1000 psi (69 bar) @ 1450 rpm (D/G10-X) 1000 psi (69 bar) @ 1750 rpm (D/G10-E) 1500 psi (103 bar) @ 790 rpm (D/G10-X)
Non-Metallic Heads:	250 psi (17 bar) Polypropylene 350 psi (24 bar) PVDF

Max Inlet Pressure	
Metallic:	250 psi (17 bar)
Non-Metallic:	50 psi (3.5 bar)

Fluid Temperature	
Metallic Heads:	250°F (121°C) – consult factory for temperatures above 160°F (71°C)
Non-Metallic Heads:	Polypropylene: 120°F (49°C); PVDF: 140°F (60°C) – consult factory for temperatures above 120°F (49°C)

Maximum Solids Size	500 microns
Inlet Port	D10: 1 inch NPT G10: 1 inch BSPT
Discharge Port	D10: 3/4 inch NPT G10: 3/4 inch BSPT
Shaft Diameter	7/8 inch (22.2 mm)
Shaft Rotation	Reverse (bi-directional)
Bearings	Tapered roller bearings
Oil Capacity	1.1 US quarts (1.04 liters)
Weight	Metallic Heads: 48 lbs (21.8 kg) Non-metallic Heads: 35 lbs (15.9 kg)

Calculating Required Horsepower (kW)*

$$\frac{15 \times \text{rpm}}{63,000} + \frac{\text{gpm} \times \text{psi}}{1,460} = \text{electric motor HP}^*$$

$$\frac{15 \times \text{rpm}}{84,428} + \frac{\text{l/min} \times \text{bar}}{511} = \text{electric motor kW}^*$$

* rpm equals pump shaft rpm. HP/kW is required application power.

When using a variable frequency drive (VFD) calculate the hp or kW at minimum and maximum pump speed to ensure the correct hp or kW motor is selected. Note that motor manufacturers typically de-rate the service factor to 1.0 when operating with a VFD.

D/G10 Specifications

Net Positive Suction Head – NPSHr

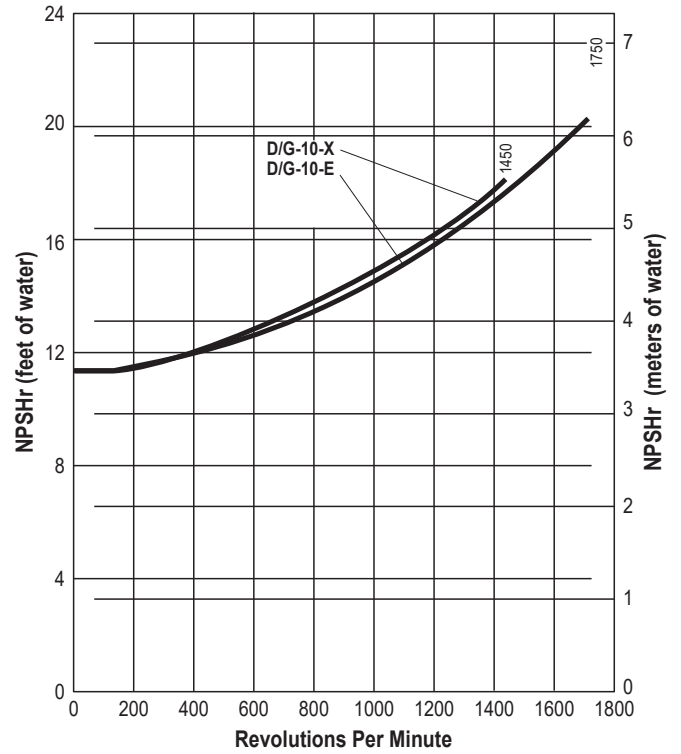

Performance

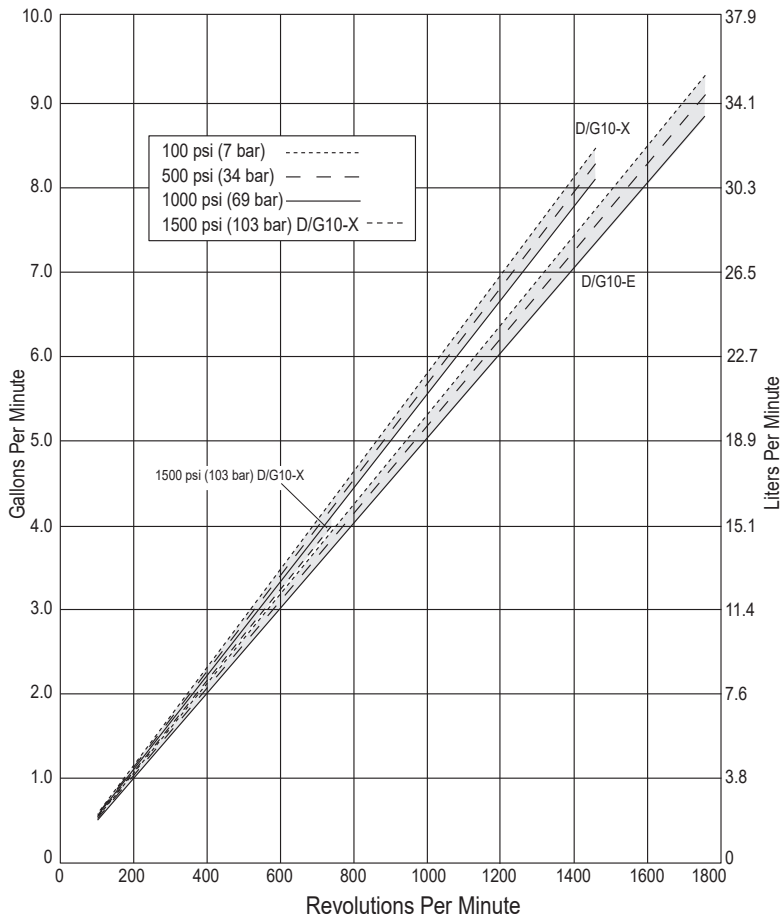

Note: Positive inlet pressure required with PTFE diaphragms.

D/G10 Dimensions

Models with Metallic Pump Head Inches (mm)

- Brass
- Cast Iron
- Duplex Alloy 2205 SST
- 316L Stainless Steel
- Hastelloy® (C Series)

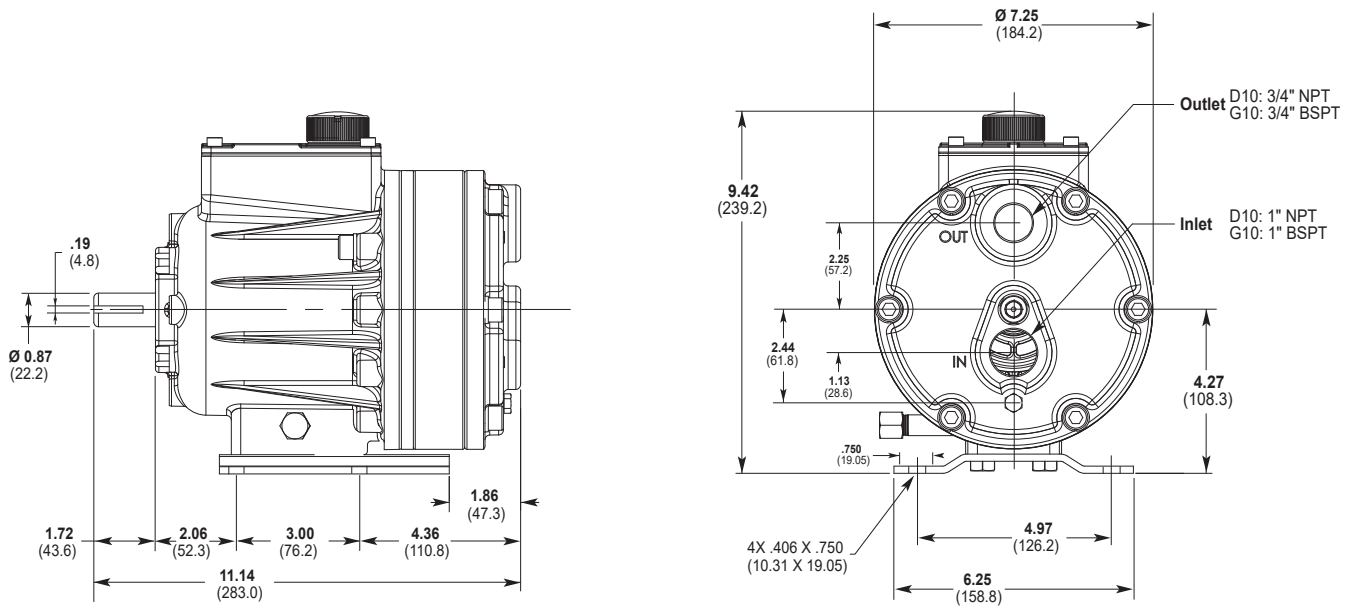

Models with Non-Metallic Pump Head Inches (mm)

- PVDF
- Polypropylene

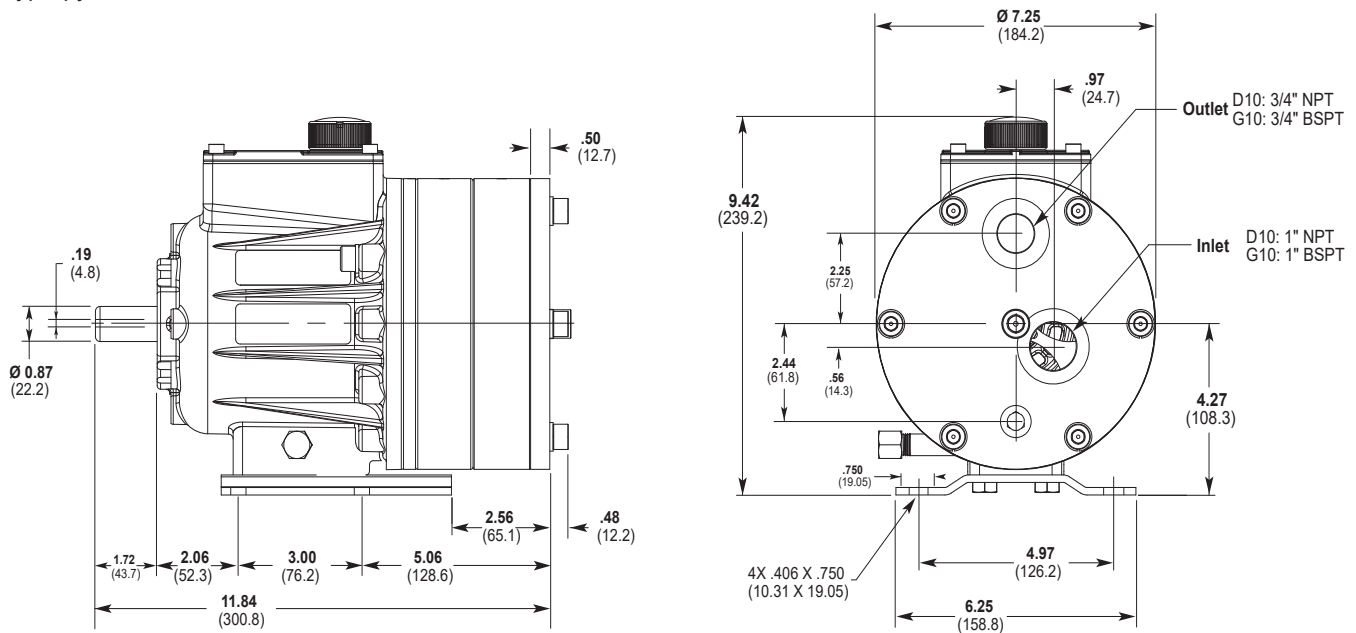

D/G10 Installation

Safety Precautions

General remarks

These safety / installation instructions contain fundamental information and precautionary notes and must be kept available to all associated with the operation of the pump. Please read them thoroughly prior to installation, electrical connection and commissioning of the unit. It is imperative that all other operating instructions relating to the components of individual units are followed.

These safety / installation instructions do not take local regulations into account. The operator must ensure that such regulations are observed by all, including the personnel carrying out the installation.

Each pump must be labeled by the end user to warn of any hazards that the system process may produce; e.g. corrosive chemicals or hot process etc.

All personnel involved in the operation, maintenance, inspection and installation of the pump must be fully qualified to carry out the work. The personnel's responsibilities, competence and supervision must be clearly defined by the operator. To the extent that if the personnel in question is not already in possession of the requisite know-how, appropriate training and instruction must be provided. In addition, the operator is responsible for ensuring that the contents of the operating instructions are fully understood by all the responsible personnel.

When installing a Hydra-Cell pump in conjunction with a motor or motor and frequency controller the relevant manuals must be referred to for electromagnetic compatibility. The installation should conform to EN 61800 and EN 60204 as applicable.

All safety instructions in this manual and all relevant local health and safety regulations must be followed.

Attention must be paid to the weight of the pump before attempting to lift either manually or selecting appropriate lifting equipment.

D/G10 Installation

Equipment Precautions

Adequate Fluid Supply. To avoid cavitation and premature pump failure, be sure that the pump will have an adequate fluid supply and that the inlet line will not be obstructed. See "Inlet Piping".

Positive Displacement. This is a positive-displacement pump. To avoid severe system damage if the discharge line ever becomes blocked, install a relief valve downstream from the pump. See "Discharge Piping". A suitable and calibrated pressure gauge should be installed in the discharge line close to the pump head.

Safety Guards. Install adequate safety guards over all pulleys, belts, and couplings. Follow all codes and regulations regarding installation and operation of the pumping system.

Shut-Off Valves. Never install shut-off valves between the pump and discharge pressure regulator, or in the regulator bypass line.

Freezing Conditions. Protect the pump from freezing. See also the Maintenance Section.

Working Pump. The pump body will become hot during operation even if the liquid being pumped is cold.

Consult the Factory for the following situations:

- Extreme temperature applications – above 160° F (71°C) or below 40° F (4.4°C)
- Pressure feeding of pumps
- Viscous or abrasive fluid applications
- Chemical compatibility problems
- Hot ambient temperatures – above 110° F (43°C)
- Conditions where pump oil may exceed 200° F (93°C) because of a combination of hot ambient temperatures, hot fluid temperature, and full horsepower load — an oil cooler may be required

Location

Locate the pump as close to the supply source as possible. Install it in a lighted clean space where it will be easy to inspect and maintain. Allow room for checking the oil level, changing the oil, and removing the pump head (manifold, valve plate and related items).

Mounting

The pump shaft can rotate in either direction. To prevent vibration, mount the pump and motor securely on a level rigid base.

On a belt-drive system, align the sheaves accurately; poor alignment wastes horsepower and shortens the belt and bearing life. Make sure the belts are properly tightened, as specified by the belt manufacturer.

On a direct-drive system, align the shafts accurately. Unless otherwise specified by the coupling manufacturer, maximum parallel misalignment should not exceed 0.015 in. (0.4 mm) and angular misalignment should be held to 1° maximum. Careful alignment extends life of the coupling, pump, shafts, and support bearings. Consult coupling manufacturer for exact alignment tolerances.

Drive couplings, belts and pulleys must be of suitable design, correctly sized, fitted, and rated for the maximum load required.

On a close-coupled system, coat the motor shaft liberally with anti-seize.

The pump, motor and related components must be adequately grounded.

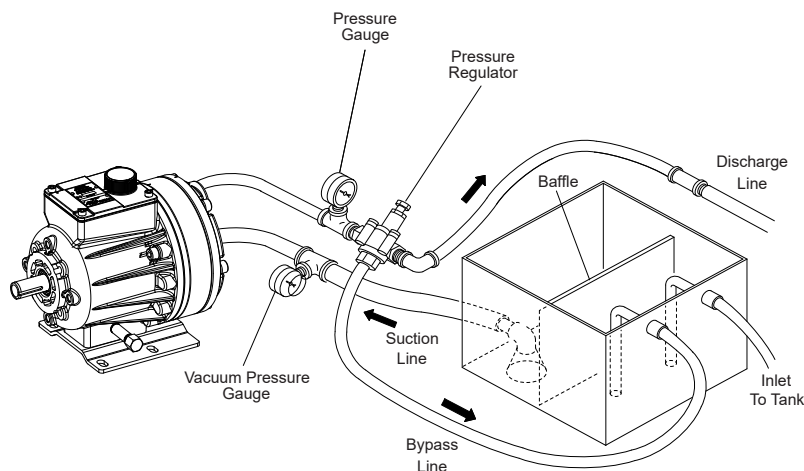

D/G10 Installation

Inlet Piping (Suction Feed)

CAUTION: When pumping at temperatures above 160° F (71°C), attention must be paid to the vapor pressure curve of the liquid. A pressure-feed system may be required.

Do not supply more than one pump from the same inlet line.

With PTFE diaphragms, the inlet must be flooded.

Install drain cocks at any low points of the suction line, to permit draining in freezing conditions.

Provide for permanent or temporary installation of a vacuum gauge to monitor the inlet suction. To maintain maximum flow, ensure the system NPSHa exceeds the NPSHr of the pump.

Supply Tank

Use a supply tank that is large enough to provide time for any trapped air in the fluid to escape. The tank size should be at least twice the maximum pump flow rate.

Isolate the pump and motor stand from the supply tank, and support them separately.

Install a separate inlet line from the supply tank to each pump.

Install the inlet and bypass lines so they empty into the supply tank below the lowest water level, on the opposite side of the baffle from the pump suction line.

Do not use a line strainer or filter in the suction line unless regular maintenance is assured. If a line strainer is used in the system, install it in the inlet line to the supply tank. It should have a free-flow area of at least three times the free-flow area of the inlet.

To reduce aeration and turbulence, install a completely submerged baffle plate to separate the incoming and outgoing liquids.

Install a vortex breaker in the supply tank, over the outlet port to the pump.

Place a cover over the supply tank, to prevent foreign objects from falling into it.

Hose and Routing

Size the suction line at least one size larger than the pump inlet, and so that the velocity will not exceed 1-3 ft/sec (0.3 to 0.9 m/s):

For pipe in mm: $\text{Velocity (m/sec)} = 21.2 \times \text{LPM/Pipe ID}^2$

For pipe in inches: $\text{Velocity (ft/sec)} = 0.408 \times \text{GPM/Pipe ID}^2$

Keep the suction line as short and direct as possible. A maximum of 1m (3 feet) is recommended.

Use flexible hose and/or expansion joints to absorb vibration, expansion, or contraction.

If possible, keep the suction line level. Do not have any high points to collect vapor unless these high points are vented.

To reduce turbulence and resistance, do not use 90° elbows. If turns are necessary in the suction line, use 45° elbows or arrange sweeping curves in the flexible inlet hose.

If a block valve is used, be sure it is fully opened so that the flow to the pump is not restricted. The opening should be at least the same diameter as the inlet plumbing ID.

Install piping supports where necessary to relieve strain on the inlet line and to minimize vibration.

D/G10 Installation

Inlet Piping (Pressure Feed)

Provide for permanent or temporary installation of a vacuum/pressure gauge to monitor the inlet vacuum or pressure. Pressure at the pump inlet should not exceed 17 bar (250 psi); if it could get higher, install an inlet pressure reducing regulator. Do not supply more than one pump from the same inlet line.

Inlet Calculations

Acceleration Head

Calculating the Acceleration Head

Use the following formula to calculate acceleration head losses. Subtract this figure from the NPSHa, and compare the result to the NPSHr of the Hydra-Cell pump.

$$H_a = (L \times V \times N \times C) \div (K \times G)$$

where:

H_a = Acceleration head (ft of liquid)

L = Actual length of suction line (ft) — not equivalent length

V = Velocity of liquid in suction line (ft/sec)

$$\text{or } V = \text{GPM} \left(\frac{0.408}{\text{Pipe ID}^2} \right)$$

N = RPM of crankshaft

C = Constant determined by type of pump — Use 0.066 for D/G10 pumps.

K = Constant to compensate for compressibility of the fluid — use: 1.4 for de-aerated or hot water; 1.5 for most liquids; 2.5 for hydrocarbons with high compressibility

G = Gravitational constant (32.2 ft/sec²)

Friction Losses

Calculating Friction Losses in Suction Piping

When following the above recommendations (under “inlet Piping”) for minimum hose/pipe I.D. and maximum length, frictional losses in the suction piping are negligible (i.e., $H_f = 0$) if you are pumping a water-like fluid.

When pumping more-viscous fluids such as lubricating oils, sealants, adhesives, syrups, varnishes, etc., frictional losses in the suction piping may become significant. As H_f increases, the available NPSH (NPSHa) will decrease, and cavitation will occur.

In general, frictional losses increase with increasing viscosity, increasing suction-line length, increasing pump flow rate, and decreasing suction-line diameter. Changes in suction-line diameter have the greatest impact on frictional losses: a 25% increase in suction-line diameter cuts losses by more than two times, and a 50% increase cuts losses by a factor of five times.

Consult the factory before pumping viscous fluids.

Minimizing Acceleration Head and Frictional Losses

To minimize the acceleration head and frictional losses:

- Keep inlet lines less than 1 m (3 ft) long.
- Use inlet hose at least one size larger than the size of the inlet port of the pump.
- Use flexible, non-collapsible suction hose and/or expansion joints to absorb vibrations, expansions and contractions.
- Minimize fittings (elbows, valves, tees, etc.)
- **Use a suction stabilizer on the inlet.**

D/G10 Installation

Net Positive Suction Head

NPSHa must be equal to or greater than NPSHr. If not, the pressure in the pump inlet will be lower than the vapor pressure of the fluid— and cavitation will occur.

Calculating the NPSHa

Use the following formula to calculate the NPSHa:

$$\text{NPSHa} = P_t + H_z - H_f - H_a - P_{vp}$$

where:

P_t = Atmospheric pressure

H_z = Vertical distance from surface liquid to pump center line (if liquid is below pump center line, the H_z is negative)

H_f = Friction losses in suction piping

H_a = Acceleration head at pump suction

P_{vp} = Absolute vapor pressure of liquid at pumping temperature

Notes:

- In good practice, NPSHa should be 2 ft (0.6 m) greater than NPSHr.
- All values must be expressed in feet of liquid.

Atmospheric Pressure at Various Altitudes

Altitude (ft)	Pressure (ft of H ₂ O)	Altitude (ft)	Pressure (ft of H ₂ O)
0	33.9	1500	32.1
500	33.3	2000	31.5
1000	32.8	5000	28.2

Discharge Piping

Note: Consult the Factory before manifolding two or more pumps together.

Hose and Routing

Use shortest, most-direct route for discharge line.

Select pipe or hose with **working pressure** rating of at least 1.5 times maximum system pressure. EXAMPLE: Select a 1500-psi W. P.-rated hose for systems to be operated at 1000-psi-gauge pressure.

Use about 6 ft (1.8 m) of flexible hose between pump and rigid piping to absorb vibration, expansion or contraction.

Support pump and piping independently. Size discharge line so that velocity of fluid will not exceed 2-3 m/sec (8-10 ft/sec):

For pipe in mm: Velocity (m/sec) = $21.2 \times \text{LPM}/\text{Pipe ID}^2$

For pipe in inches: Velocity (ft/sec)

$$\text{or } V = 0.408 \left(\frac{\text{GPM}}{\text{Pipe ID}^2} \right)$$

Note: Pumps with non-metallic pumping head are limited to 17 bar (250 psi) maximum working pressure rating.

Pressure Regulation

Install pressure regulator or unloader in discharge line. Bypass pressure must not exceed pressure limit of pump.

Size regulator so that, when fully open, it will be large enough to relieve full capacity of pump without over pressurizing the system.

Locate regulator as close to pump as possible and ahead of any other valves.

Adjust pressure regulator valve to no more than 10% over maximum working pressure of system. Do not exceed manufacturer's pressure rating for pump or regulator.

Route the bypass line to the supply tank, not to the suction line (to reduce the chance of turbulence and cavitation within the pump).

If the pump may be run for a long time with the discharge closed and fluid bypassing, install a thermal protector in the bypass line (to prevent severe temperature buildup in the bypassed fluid).

The safety, pressure regulating valve must be checked for correct operation on a regular basis.

CAUTION: Never install shutoff valves in the bypass line or between the pump and pressure regulator or relief valve.

Provide for permanent or temporary installation of pressure gauge to monitor discharge pressure at pump.

For additional system protection install safety relief valve in discharge line downstream from pressure regulator.

D/G10 Installation

Before Initial Start-Up

Before you start the pump, be sure that:

- All shut-off valves are open, and pump has adequate supply of fluid.
- All connections are tight.
- The oil is at the correct level, ¼ in. (6 mm) from the bottom of the fill port.
- The relief valve on the pump outlet is adjusted so the pump starts under minimum pressure.
- All pulleys and belts are properly aligned, and belts are tensioned according to specification.
- All pulleys and belts have adequate safety guards.
- Ensure that the materials of construction of the pump are compatible with the liquid being pumped.

Initial Start-Up Procedure

1. Turn on power to pump motor.
2. Check inlet pressure or vacuum. To maintain maximum flow, inlet vacuum must not exceed 180 mm Hg at 21°C (7 in. Hg at 70° F). Inlet pressure must not exceed 17 bar (250 psi).
3. Listen for any erratic noise and look for unsteady flow.
4. If system has airlock and pump fails to prime:
 - a. Turn off power.
 - b. Remove pressure gauge or plug from tee fitting at pump outlet (refer to illustration drawing at the front of this section).

Note: Fluid may come out of this port when the plug is removed. Provide an adequate catch basin for fluid spillage, if required. Fluid will come out of this port when the pump is started, so we recommend that you attach adequate plumbing from this port so fluid will not be sprayed or lost. Use high-pressure-rated hose and fittings from this port. Take all safety precautions to assure safe handling of the fluid being pumped.

 - c. Jog system on and off until fluid coming from this port is air-free.
 - d. Turn off power.
 - e. Remove plumbing that was temporarily installed, and reinstall pressure gauge or plug.
5. Adjust discharge pressure regulator to desired operating and bypass pressures. Do not exceed maximum pressure rating of pump.
6. After pressure regulator is adjusted, set safety relief valve at 7 bar (100 psi) higher than desired operating pressure. To verify this setting, adjust discharge pressure regulator upward until relief valve opens. Follow recommendations in **Step 4b Note** for handling fluid that will come from relief valve.
7. Reset discharge pressure regulator to desired system pressure.
8. Provide return line from relief valve to supply tank, similar to bypass line from pressure regulator.

D/G10 Maintenance

Note: The numbers in parentheses are the Reference Numbers on the exploded view illustrations found in this manual and in the Parts Section.

Daily

Check oil level and condition of oil. The oil is at the correct level, ¼ in. (6 mm) from the bottom of the fill port.

Use the appropriate Hydra-Oil for the application (contact Wanner Engineering if in doubt).

CAUTION: If you are losing oil but don't see any external leakage, or if the oil becomes discolored and contaminated, one of the diaphragms (43) may be damaged. Refer to the Fluid-End Service Section. Do not operate the pump with a damaged diaphragm.

CAUTION: Do not leave contaminated oil in the pump housing or leave the housing empty. Remove contaminated oil as soon as discovered, and replace it with clean oil.

Periodically

Change the oil after the first 100 hours of operation, and then according to the guidelines below.

Hours Between Oil Changes @ Various Process Fluid Temperatures

Pressure	RPM	<90°F (32°C)	<139°F (60°C)	<180°F (82°C)
Metallic Pump Head				
<650 psi (45 bar)	<1200	6,000	4,500	3,000
	<1800	4,000	3,000	2,000
<1000 psi (69 bar)	<1200	4,000	3,000	2,000
	<1800	2,000	1,500	1,000
Non-Metallic Pump Head				
<250 psi (17 bar)	<1200	4,000	3,000	—
	<1800	2,000	1,500	—

Note: Minimum oil viscosity for proper hydraulic end lubrication is 16-20 cST (80-100 SSU).

Note: Use of an oil cooler is recommended when process fluid and/or hydraulic end oil exceeds 180°F (82°C) for Metallic Pump Head models or when hydraulic end oil exceeds 180°F (82°C) for Non-Metallic Pump Head models.

When changing, remove the drain pipe cap (10) at the bottom of the pump so all oil and accumulated sediment will drain out.

CAUTION: Do not turn the drive shaft while the oil reservoir is empty.

Check the inlet pressure or vacuum periodically with a gauge. If vacuum at the pump inlet exceeds 7 in. Hg (180 mm Hg), check the inlet piping system for blockages. If the pump inlet is located above the supply tank, check the fluid supply level and replenish if too low.

CAUTION: Protect the pump from freezing. Refer also to the "Shutdown Procedure".

Shutdown Procedure During Freezing Temperatures

Take all safety precautions to assure safe handling of the fluid being pumped. Provide adequate catch basins for fluid drainage and use appropriate plumbing from drain ports, etc., when flushing the pump and system with a compatible antifreeze.

1. Adjust discharge pressure regulating valve so pump runs under minimum pressure. Stop pump.
2. Drain supply tank; open any draincocks in system piping and collect drainage; remove pipe cap (10) from manifold and collect drainage.
3. Close draincocks in system piping and replace manifold plug.
4. Fill supply tank with enough antifreeze to fill system piping and pump.

Note: Disconnect the system return line from the supply tank and connect it to a separate reservoir.

5. Start pump and allow it to run until system is filled with antifreeze.

Note: If the system has an air lock and the pump fails to prime, follow step 4 of the Initial Start-up Procedure to clear the air.

6. When mostly antifreeze is flowing from system return line, stop pump. Connect system return line back to supply tank and circulate antifreeze for short period.
7. It is also good practice to change oil in hydraulic end before storage for an extended period. This will remove any accumulated condensation and sediment from oil reservoir. Drain and refill hydraulic end with appropriate Hydra-Oil and operate pump for short period to assure smooth performance.

D/G10 Fluid End Service

Note: The reference numbers in parentheses are shown in the Fluid End Parts Section.

This section explains how to disassemble and inspect all easily-serviceable parts of the pump fluid end.

Caution: Disassembly of the fluid end of the pump should be performed only by a qualified technician. For assistance, contact Wanner Engineering (612-332-5681) or the distributor in your area.

Note: The following service procedures refer several times to the Wanner Tool Kit (P/N A03-175-1101). Wanner strongly recommends the use of this tool kit when repairing or servicing the pump (available from Wanner or your local distributor).

1. Remove Manifold (62), Valve Plate (63)

- Remove six bolts (51) and six washers (9) around manifold (62). Do not remove bolt (3) or bolt (8) installed through back of cylinder housing (40).
- Use 3/8-in. (10-mm) hex Allen wrench to remove center bolt (52) and washer (50).
CAUTION: Do not turn the pump drive shaft while the manifold and valve plate are off the pump, except when removing diaphragms or repriming the hydraulic cells.
- Remove manifold (62), and support plate (66) [Non-metallic pump head only.] Valve plate (63) will remain on cylinder housing (40).
- Inspect manifold (62) for warping or wear around inlet and outlet ports. If wear is excessive, replace the manifold.
To check if manifold is warped, remove O-rings (57,59,60) and place straightedge across it. If warped, replace.

2. Inspect Valves (54-57, 64, 65, 67)

The three inlet and three outlet valve assemblies are identical but face opposite directions. Inspect each valve as follows:

- Check the spring retainer (64), and replace if worn.
Note: if your pump has a non-metallic pump head there will be a plastic dampening washer (65) at the bottom of each seat. Inspect each one for wear or cracks and replace if necessary.
- Check valve spring (56). If shorter than new spring, replace (Do not stretch old spring.)
- Check valve (55). If worn excessively, replace.
Note: If your pump has plastic spring retainers, there is a tetra seal (flat O-ring, 67) between retainer (64) and valve seat (54).
- Remove valve seat (54) and O-ring (57). A seat puller is included in the Wanner Tool Kit. On cast iron valve plates, be careful not to break metal ridge around O-ring groove. Inspect valve seat for wear, and replace if necessary. A new O-ring should be installed.
- Reinstall the inlet and outlet valve assemblies:
 - Clean valve ports and shoulders with emery cloth, and lubricate with lubricating gel or petroleum jelly.
 - Install O-ring (57) on valve seat (54).
 - Inlet Valves (3 center valves in illustration below).** Insert spring retainer (64) into valve plate (63). Then insert spring (56), valve (55), and valve seat (54). If pump has plastic spring retainers, install flat Tetra seal O-ring (67) between spring retainer and valve seat. Insert dampening washer (65), if included in your valve assembly.
 - Outlet Valves (3 outer valves in illustration below).** Insert dampening washer (65), if included in your valve assembly. Insert valve seat (54), valve (55), spring (56), and spring retainer (65). If the pump has plastic spring retainers, install flat Tetra seal O-ring (67) between spring retainer and valve seat. If the pump has metal spring retainers in outlet valves, position them so a leg does not point toward the center of the pump (See illustration below.)

Valve Retainer Orientation In Valve Plate

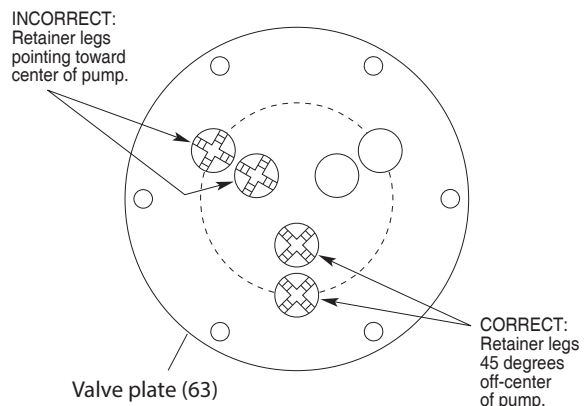

D/G10 Fluid End Service

3. Inspect and Replace Diaphragms (43)

If necessary to service diaphragms, remove two socket-head cap screws (58) that secure valve plate (63) to cylinder housing (40). Inspect valve plate the same as manifold in Paragraph 1, step d.

- a. Lift diaphragm (43) by one edge, and turn pump shaft (**use the shaft rotator from the Wanner Tool Kit**) until diaphragm pulls up. This will expose machined cross-holes in plunger shaft behind diaphragm.
- b. Insert plunger holder (**from the Wanner Tool Kit**) through one of machined cross holes to hold diaphragm up. Don't remove tool until new diaphragm is installed in step f below.
- c. Remove the screw (46), O-ring (45), and follower (44) in center of diaphragm (43).
- d. Remove diaphragm (43), and inspect carefully. A damaged diaphragm generally indicates a pumping system problem. Replacing diaphragm only will not solve the larger problem. Inspect diaphragm for following:
 - **Puncture.** Usually caused by sharp foreign object in fluid.
 - **Diaphragm pulled away** from center screw or from cylinder sides. Usually caused by fluid being frozen in pump, or by over-pressurization of pump.
 - **Diaphragm becoming stiff** and losing flexibility. Usually caused by pumping fluid that is incompatible with diaphragm material.
 - **Diaphragm edge chewed away.** Usually caused by over-pressurizing system.
- e. Inspect plunger (42) for any rough surfaces or edges. **Do not** remove plunger from plunger shaft. Smooth surfaces and edges as necessary with emery cloth or fine file.

CAUTION: If a diaphragm has ruptured and foreign material or water has entered the oil reservoir, do not operate the pump. Check all diaphragms, then flush the reservoir completely (as outlined below) and refill it with fresh oil. Never let the pump stand with foreign material or water in the reservoir, or with the reservoir empty.

- f. Install new diaphragm (43) ridge side out.
- g. Clean screw (46) and remove any oil from it. Apply medium-strength thread locker to screw. Reinstall screw and follower (44), and new O-ring (45). Tighten to 18 in-lbs (2.0 N-m).
- h. Repeat above inspection procedure (and replacement, as necessary) with other two diaphragms.

4. Flush Contaminant from Hydraulic End

Only if a diaphragm has ruptured

- a. Remove the brass cap (10) and allow all oil and contaminants to drain out.
- b. Fill reservoir with compatible solvent. Manually turn pump shaft to circulate compatible solvent and drain. Dispose of contaminated fluid properly.

CAUTION: If you have an EPDM diaphragm, or if food grade oil is in the reservoir, do not use kerosene or solvents. Instead, flush with the same lubricant that is in the reservoir.
- c. Repeat step b. flushing procedure.
- d. Fill reservoir with fresh oil and manually turn pump shaft to circulate oil. Drain oil.
- e. Refill reservoir with fresh oil. If oil appears milky, there is still contaminant in reservoir. Repeat steps c and d until oil appears clean.

D/G10 Fluid End Service

5. Priming Hydraulic Cells

Note: Providing oil prime to fitted pumps requires pressure be applied to the diaphragms. This can be done manually, with the system head pressure, or with pressurized air if available. Review all methods below to determine the procedure most suitable.

Method 1 (system head pressure less than 2 psi)

- Install valve plate (63) but without the outlet valves installed (or else remove outlet valves; leave seats installed) onto cylinder housing (40). Tighten two socket-head screws (58).
- Fill reservoir with correct Hydra-oil to fill port.
- With blunt pointer (eraser end of pencil), reach in through each outlet valve port and push diaphragm (43) backwards. Note air bubbles coming out at oil fill port. Now turn shaft about 1/2 turn.
- Repeat depressing diaphragms (43) and rotating shaft (approximately 4 to 6 times) until no more air bubbles escape and oil has dropped about 1 inch (25 mm) from top of fill port. Hydraulic cells are now primed. Replace oil fill cap (5).
- Install outlet valve assemblies in each outlet valve port. See Parts list for correct assembly order. If necessary, tip pump (head upward) to keep valve (55) centered on valve seat (54) and allow valve retainer (64) to fit into port flush.
- Install manifold (62) and complete installation.

Alternative Method 1 (system head pressure less than 2 psi)

- With pump horizontal, and the fluid-end head removed, fill reservoir with correct Hydra-oil to fill port.
- Have catch basin for oil that leaks from behind diaphragms when priming. Catch oil and dispose of properly. **Do not reuse oil.**
- All air in oil within hydraulic piston behind diaphragms (43) must be forced out by turning shaft (and pumping piston). A shaft rotator is included in the Wanner Tool Kit. Keep pressure on diaphragms while turning shaft until bubble-free flow of oil comes from behind all diaphragms. Maintain oil level in reservoir. Do not allow oil level to be lower than reservoir.
- Before oil runs out past diaphragms (43), quickly attach loaded valve plate (63) with socket head screws (58). Do not tighten screws completely. Leave gap between valve plate and the cylinder housing (40). Turn shaft 2-3 turns to finish forcing out air behind diaphragms. Hydraulic cells are now primed. Finish tightening valve plate with two socket head screws (51) and add pump manifold (62).
- Wipe excess oil from around pump head.
- Check that oil level is 1 inch (25 mm) from top of fill port.
- Replace oil fill cap (5) and complete installation.

Method 2 (head pressure greater than 2 psi)

This simple and clean method of priming Hydra-cells requires an inlet head pressure of at least 5 feet (1.5 m) or 2 psi (.14 bar). The pressure source is required to hold the diaphragms back while the piston moves so as to force out the air.

- Completely assemble pump and fill reservoir with correct Hydra-oil to fill port.
- When tank head pressure is being used to prime**, install pump back into system and connect tank supply line to pump inlet. Pump discharge line may be connected at this time, but end of line must be open to allow air to pass out.
- Slowly turn pump shaft by hand and watch for bubbles exiting oil reservoir fill opening. This will take several rotations; when no more bubbles come out and reservoir level has dropped about 1" (25 mm), hydraulic cells are primed.
- Replace oil fill cap (5) and complete installation.
- When compressed air is being used to prime**, insert clean air hose to pump inlet and restrict pump outlet. Turn shaft quarter turn and then apply air pressure into manifold to put pressure on diaphragms (43). This will force air out from inside pistons. Observe for bubbles at reservoir opening. Repeat for several rotations until no more air bubbles come out and reservoir level has dropped about 1" (25 mm). Hydraulic cells are now primed.
- Replace oil fill cap (5) and complete installation.

6. Reinstall Valve Plate (63), Manifold (62),

Note: Use the cap screw (29) protruding through the cylinder casting at the 10 o'clock position to locate the valve plate on the cylinder casting. Place the "blind hole" on the valve plate over this bolt.

- With valve assemblies installed as outlined above, reinstall valve plate (63) onto cylinder housing (40). Recheck that blind hole is over protruding bolt at 10 o'clock position. Install two socket-head cap screws (58) and secure valve plate to cylinder casting.
- Reinstall O-rings (57,59,60) on rear side of the manifold (62). Use a compatible petroleum jelly or lubricating gel to hold them in place.
- Reinstall manifold (62) onto valve plate (63). Be sure drain pipe cap (10) is installed in manifold.

Note: On pumps with non-metallic head, position support plate (66) onto manifold with ports and bolt holes aligned correctly.

- Insert bolts (51) and washers (9). Hand tighten.
- Reinstall center bolt (52) with washer (50), and torque to 45 ft-lbs (60 N-m).
- Alternately tighten six perimeter bolts (51). Torque to 45 ft-lbs (60 N-m).
- Recheck all bolts for tightness.

D/G10 Hydraulic End Service

Note: The reference numbers in parentheses are shown in the Hydraulic End Parts section.

CAUTION: Do not disassemble the hydraulic end of the pump unless you are a skilled mechanic. For assistance, contact Wanner Engineering (612-332-5681) or the distributor in your area.

CAUTION: The two bolts (3 and 8) that screw through the back of the pump housing (1) into the cylinder housing (40) hold the two housings together. Do not remove the bolts except when repairing the hydraulic end.

Note: The following service procedures refer several times to the Wanner Tool Kit (P/N A03-175-1101). Wanner strongly recommends the use of this tool kit when repairing or servicing the pump (available from Wanner or your local distributor).

1. Remove Pump Housing

- a. Remove head of pump, and diaphragms, as outlined in the Fluid-End Service Section.
- b. Drain oil from pump housing by removing pipe cap (10).
- c. Set hydraulic end of pump face-down on cylinder housing (40), onto smooth, clean surface.
- d. Check shaft for sharp burrs. Smooth any burrs, to prevent scarring housing seals (64) when you disassemble pump.
- e. Remove bolts (3 or 8) that secure housing to cylinder housing. Piston return springs (50) will force cylinder housing and housing apart.

Note: When reassembling later, note that one bolt (3) is 1/4 in. (7 mm) longer than the other (8). The longer bolt must be installed in the 10 o'clock position of the cylinder housing (40).

- f. Lift off housing (1).
- g. Inspect cam and bearings (71), and bearing race in rear of pump housing. If bearings are pitted or binding, or if housing race is worn, replace them both.

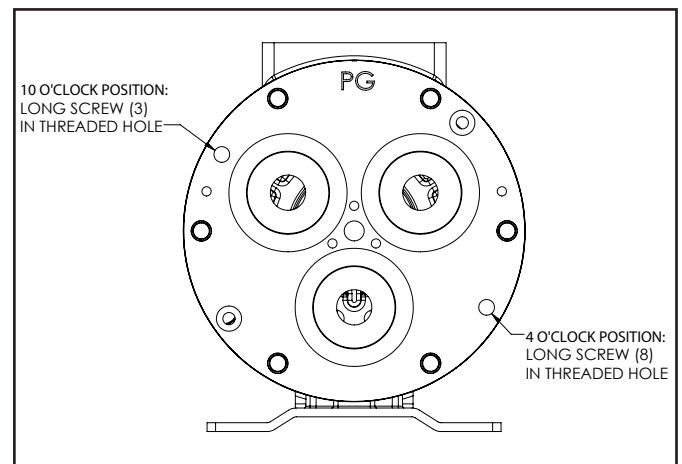

D/G10 Hydraulic End Service

2. Disassemble Pistons

- a. With pump housing removed (see above), turn unit over and set it on flat surface, piston side down.
- b. With diaphragms removed (see Fluid-End Service Section), reinsert follower screw (46) into hole in one of valve plungers (31). Tap screw lightly with hammer and plunger (42) should slip off valve plunger (54).

Hydraulic piston assembly (54-56, 64,65,67) can now be disassembled. Inspect all parts, and replace all O-rings and any other parts that are worn or damaged.

- c. Repeat step b. for remaining pistons.

Note: When you reassemble the hydraulic piston, use new plungers (42). They are press-fit onto the valve plungers (31) and are not reusable.

3. Reassemble Pistons

- a. Drop ball (27) into each opening in bottom of piston assembly (26).
- b. Insert retaining washer (25) and O-ring (57) to hold balls in place.
- c. Insert valve plunger (31) into valve cylinder (30). Slide spring (35) over plunger, inside valve cylinder.
- d. Insert O-ring (33) into spring retainer (34).
- e. Slide assembled valve cylinder, plunger, and spring (30-32) into spring retainer (34).
- f. Slide complete cylinder-and-retainer assembly (30-35, 48,49) into piston assembly (24,25,26).
- g. Insert return spring (35) into piston assembly, wide end first. This is tight fit, and can best be done by turning spring counterclockwise.
- h. Repeat above procedure for other two pistons.

4. Reassemble Pump Housing and Cylinder Housing

Note: Inspect the shaft seals (2) before continuing. If they look damaged in any way, replace them (remove by pounding them out from inside the pump housing). Both seals should be replaced at the same time. Clean the bore in the housing using emery cloth or ScotchBrite™.

- a. Place cylinder housing (40) face-down on flat surface.
- b. Insert assembled pistons (54-56, 64,65,67) into cylinder housing. Holes on foot end of pistons should all point toward center of housing.
- c. Note location of outer ring of holes in cylinder housing and in pump housing flange (in particular, holes where bolts (3) and (8) will be installed).
- d. Stand camshaft assembly (71) on cylinder housing (40).

CAUTION: The pilot bearing MUST be properly nested in the bearing race during assembly. If misaligned, the bearing will be damaged and the pump will fail within the first hours of operation.

- e. Using petroleum jelly or grease to retain it, install O-ring (36) and slide housing (1) down over shaft. Be sure holes in housing and the cylinder housing are properly aligned.
- f. Install two assembly studs (from Wanner Tool Kit), washers and nuts on threaded studs, but don't tighten yet. You may want to insert two or more bolts (51) into unthreaded holes of housing and cylinder housing to help align parts.
- g. Alternately tighten the nuts of assembly studs to evenly draw housing down to cylinder housing. Be sure O-ring (36) stays in place.

Also, as you tighten nuts keep checking shaft alignment by turning shaft (use rotator in Wanner Tool Kit). If shaft begins to bind and become difficult to turn, back off nuts and realign shaft. When housing is tight against cylinder housing, you should be able to turn shaft smoothly.

- h. After pump housing and cylinder housing are together, insert bolt (8) with lock washer (9) (at 4 o'clock position) through pump housing and into cylinder housing. Repeat with bolt (3) in 10 o'clock position. Tighten evenly and then remove assembly studs.
- i. Turn shaft again to check its alignment.

D/G10 Hydraulic End Service

5. Replace Shaft Seals

- a. Apply thin film of grease on seal protector tool (part of Wanner Tool Kit). Slide both seals onto tool, with spring side of seals toward open end of tool.
Apply heavier coat of grease between seals and press together.
- b. Apply coating of Loctite® High-Performance Pipe Sealant with PTFE, or comparable product, to outer surface of both seals and inside surface of the opening in pump housing where seals will rest.
- c. Apply light film of grease to drive shaft. Slide seal protector tool (with two seals) over end of shaft.
- d. Slide seal inserter tool (from Wanner Tool Kit) over seal protector tool, and press seals completely into place. Tap tool with soft mallet to firmly seat seals.

6. Adjust Cam Shaft Endplay

- a. Remove three set screws (41) from cylinder housing (40), and clean them.
- b. Insert center bolt (52) into hole in center of cylinder housing. Turn it in to move bearing adjusting plate (39) and cup tight against bearing cone.
- c. Back out center bolt two full turns, then turn it back in again until it is tight against adjusting plate (39).
- d. Back out the center bolt exactly 1/4 of a turn.
- e. With plastic mallet (or regular mallet and wooden board) to prevent damage to shaft, rap end of shaft 3 or 4 times. This will provide about 0.006 in. (0.15 mm) endplay in shaft.
- f. Apply removable threadlocker to threads of three cleaned set screws (41) and screw into cylinder housing until they contact bearing housing (39).
- g. Remove center bolt (52).

7. Install Plungers

Note: If the plungers (42) have been removed from the valve plungers (42), do not reuse them. Install new ones instead.

- a. Rotate pump shaft so piston is at top-dead-center position.
- b. Place plunger on exposed screw end of plunger guide tool (from Wanner Tool Kit). Larger-diameter side of plunger should face tool.
- c. Screw guide (with plunger) into valve plunger (31) until tight.
- d. Hold single bottom handle of guide, and turn double top handle to force plunger to seat on valve plunger. This is press-fit. When installed, plunger should be tight against shoulder of valve plunger.

Note: Do not remove the plunger guide until the diaphragm is installed (see below).

- e. Install diaphragm as outlined below, then repeat procedure for other two plungers and diaphragms.

8. Reinstall Diaphragms

- a. With plunger guide tool still screwed into valve plunger (31), pull valve plunger up until cross-holes in valve plunger are exposed.
- b. Insert diaphragm Allen wrench (from Wanner Tool Kit), through top hole — to hold plunger (42) away from cylinder housing. This will also keep valve plunger from turning when diaphragm is being installed.
- c. Place diaphragm (43) onto plunger (42) ridge-side out.
- d. Center diaphragm follower (44) on diaphragm.
- e. Place O-ring (45) onto follower screw (46).
- f. Apply small amount of threadlocker to threads of follower screw.
- g. Insert follower screw (with O-ring) through diaphragm follower (44) and diaphragm (43), and screw it into valve plunger (31).
- h. Hold plunger holder, and torque follower screw to 18 in.-lbs (2.0 N-m).
- i. Repeat above procedure for plungers and diaphragms of other two cylinders.
- j. Fill reservoir with fresh oil and prime pump, as outlined in Fluid-End Service Section.

9. Reassemble Pump Head

Reassemble pump head as outlined in Fluid-End Service Section.

D/G10 Fluid End Parts

Metallic Pump Head

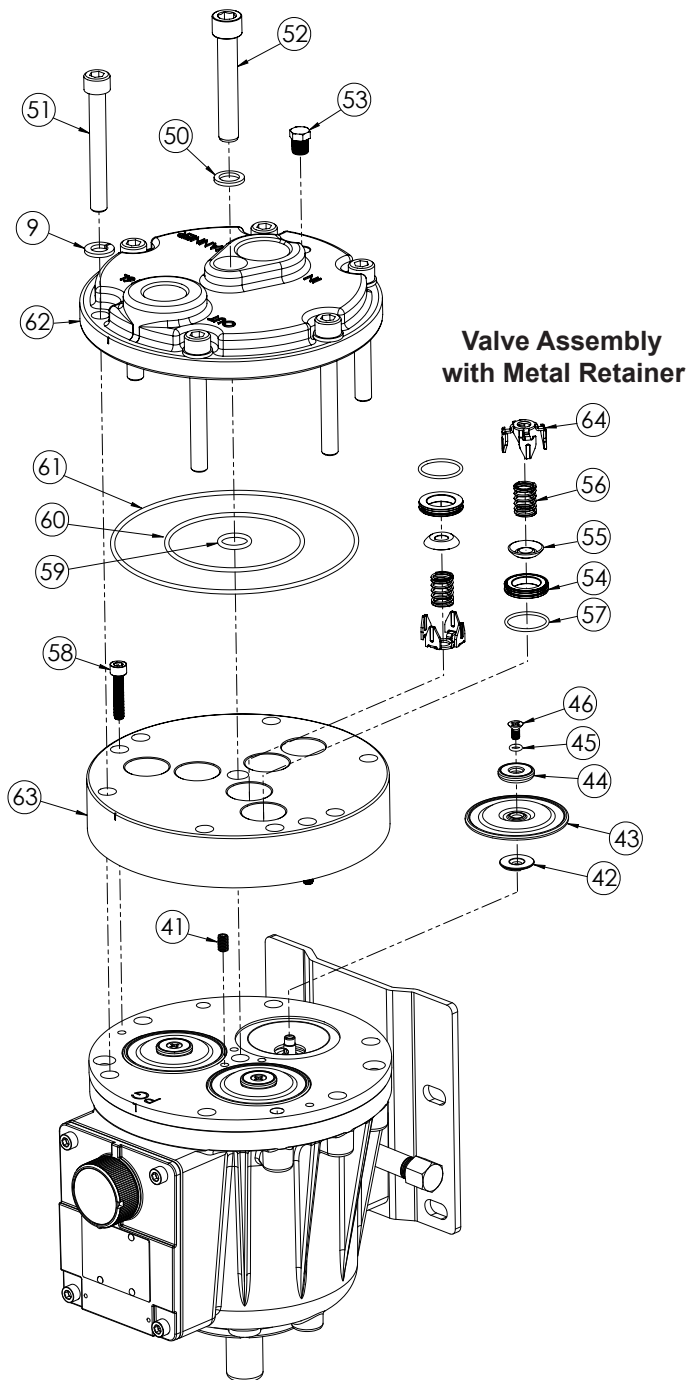

Non-Metallic Pump Head

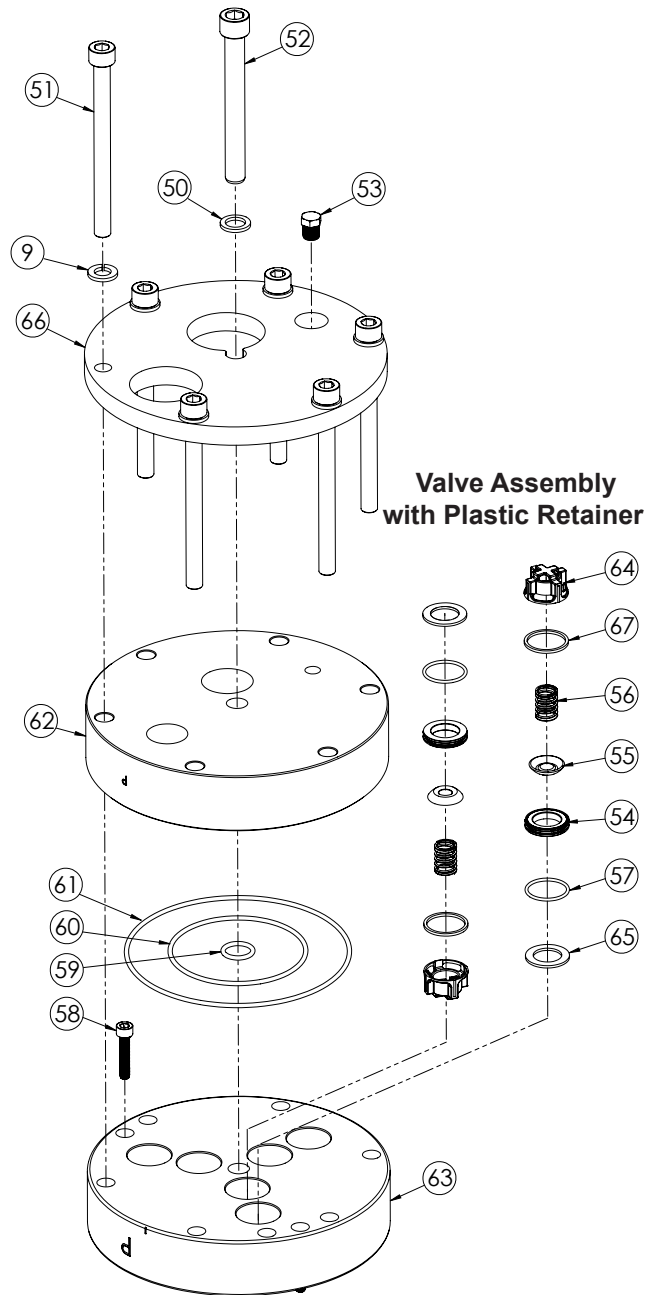

D/G10 Fluid End Parts

Ref. No.	Part Number	Description	Quantity/ Pump	Ref. No.	Part Number	Description	Quantity/ Pump
9	G25-048-2010	Washer, Split lock.....	8	59	D10-083-2110	O-ring, Center bolt, Buna-N.....	1
41	G10-082-2010	Set Screw, 10 mm	3		D10-083-2111	O-ring, Center bolt, FKM.....	1
42	D10-016-1010	Plunger	3		D10-083-2112	O-ring, Center bolt, Neoprene	1
43	D10-018-2312	Diaphragm, Neoprene.....	3		D10-083-2113	O-ring, Center bolt, EPDM.....	1
	D10-018-2313	Diaphragm, EPDM	3		D10-083-2118	O-ring, Center bolt, PTFE	1
	D10-018-2315	Diaphragm, FKM.....	3	60	D11-073-2120	O-ring, Inner manifold, Buna-N.....	1
	D10-018-2320	Diaphragm, Buna-N	3		D11-073-2121	O-ring, Inner manifold, FKM	1
	D10-018-2322	Diaphragm, FFKM.....	3		D11-073-2122	O-ring, Inner manifold, Neoprene	1
	D10-018-2325	Diaphragm, Aflas.....	3		D11-073-2123	O-ring, Inner manifold, EPDM.....	1
	D10-018-2328	Diaphragm, Butyl.....	3		D10-073-2118	O-ring, Inner manifold, PTFE	1
	D10-018-2348	Diaphragm, PTFE†	3	61	D11-074-2120	O-ring, Outer manifold, Buna-N.....	1
44	D10-017-1010	Follower, 316 SST	3		D11-074-2121	O-ring, Outer manifold, FKM.....	1
	D10-017-1011	Follower, Hastelloy® C.....	3		D11-074-2122	O-ring, Outer manifold, Neoprene	1
45	D10-047-2110	O-ring, BUNA	3		D11-074-2123	O-ring, Outer manifold, EPDM.....	1
	D10-047-2111	O-ring, FKM	3		D10-074-2118	O-ring, Outer manifold, PTFE	1
	D10-047-2112	O-ring, NEOPRENE.....	3		D10-109-2110	O-ring, Outer manifold, Buna-N*	1
	D10-047-2113	O-ring, EPDM.....	3		D10-109-2111	O-ring, Outer manifold, FKM*	1
	D10-047-2118	O-ring, PTFE.....	3		D10-109-2112	O-ring, Outer manifold, Neoprene*	1
46	D10-030-2010	Screw,.....	3		D10-109-2113	O-ring, Outer manifold, EPDM*	1
50	G10-084-1010	Washer, Flat, SST	1		D10-109-2118	O-ring, Outer manifold, PTFE*.....	1
51	G10-024-2011	Screw, Cap, soc-hd, M10, 80 mm	6	62	D10-004-1002	Manifold, 316L SST, NPT	1
	G25-024-2010	Screw, Cap, soc-hd, M10, 120 mm*	6		D10-004-1008	Manifold, Brass, NPT	1
52	G10-081-2010	Screw, Cap, soc-hd, M12, 70 mm	1		D10-004-1017	Manifold, Hastelloy® C NPT.....	1
	G10-081-2017	Screw, Cap, soc-hd, M12, 102 mm*	1		D10-004-1029	Manifold, Duplex 2205, SST, NPT	1
53	D10-038-2017	Plug, Hastelloy® C, NPT	1		D10-004-1034	Manifold, Cast iron, NPT	1
	D10-038-2210	Plug, Brass, NPT.....	1		D10-004-1050	Manifold, Polypropylene, NPT*.....	1
	D10-038-2211	Plug, 316 SST, NPT	1		D10-004-1053	Manifold, PVDF, NPT*	1
	G10-038-2017	Plug, Hastelloy® C, BSPT	1		G10-004-1002	Manifold, 316L SST, BSPT.....	1
	G10-038-2211	Plug, 316 SST, BSPT	1		G10-004-1008	Manifold, Brass, BSPT	1
54	D10-020-1010	Valve seat, 17-4 SST.....	6		G10-004-1017	Manifold, Hastelloy® C, BSPT	1
	D10-020-1011	Valve seat, 316 SST.....	6		G10-004-1029	Manifold, Duplex 2205, SST, BSPT....	1
	D10-020-1016	Valve seat, Tungsten Carbide	6		G10-004-1034	Manifold, Cast iron, BSPT	1
	D10-020-1017	Valve seat, Hastelloy® C.....	6		G10-004-1050	Manifold, Polypropylene, BSPT*.....	1
	D10-020-3300	Valve seat, Ceramic	6		G10-004-1053	Manifold, PVDF, BSPT*	1
55	D10-021-1011	Valve, Nitronic® 50.....	6	63	D10-003-1032	Valve Plate, Reduced Pocket, Brass ..	1
	D10-021-1015	Valve, 17-4 SST, HT	6		D10-003-1033	Valve Plate, Reduced Pocket, 316L	1
	D10-021-1016	Valve, Tungsten carbide.....	6			SST	1
	D10-021-1017	Valve, Hastelloy® C.....	6		D10-003-1036	Valve Plate, Reduced Pocket, Cast iron	1
	D10-021-3300	Valve, Ceramic	6			1
56	D10-022-3116	Valve Spring, 17-7 SST, HT.....	6		D10-003-1037	Valve Plate, Reduced Pocket, Hastelloy® C	1
	D10-022-3117	Valve Spring, Elgiloy®.....	6		D10-003-1038	Valve Plate, Reduced Pocket, Duplex ..	1
	D10-022-3123	Valve Spring, Hastelloy® C	6			2205, SST	1
57	D10-035-2110	O-ring, Valve seat, Buna-N.....	6		D10-003-1060	Valve Plate, Reduced Pocket,	1
	D10-035-2111	O-ring, Valve seat, FKM.....	6			Polypropylene*	1
	D10-035-2112	O-ring, Valve seat, Neoprene	6		D10-003-1063	Valve Plate, Reduced Pocket, PVDF* ..	1
	D10-035-2113	O-ring, Valve seat, EPDM.....	6			1
	D10-035-2118	O-ring Valve seat, PTFE	6			1
58	G10-088-2010	Screw, Cap, soc-hd, 30 mm	2			1

*Non-metallic pump head

D/G10 Fluid End Parts

Ref. No.	Part Number	Description	Quantity/ Pump
64	D10-023-1010	Retainer, Valve spring, 17-7 SST, HT	6
	D10-023-1017	Retainer, Valve spring, Hastelloy® C	6
	D10-023-2310	Retainer, Valve Spring, Celcon®	6
	D10-023-2326	Retainer, Valve spring, Nylon	6
	D10-023-2327	Retainer, Valve spring, Polypropylene	6
	D10-023-2328	Retainer, Valve spring, PVDF	6
65	D10-125-2327	Washer, Dampening, Polypropylene*	6
	D10-125-2328	Washer, Dampening, PVDF*	6
66	D10-100-1010	Support Plate*	1
67	D10-092-2110	Tetra Seal, Buna-N	6
	D10-092-2111	Tetra Seal, FKM	6
	D10-092-2112	Tetra Seal, Neoprene	6
	D10-092-2113	Tetra Seal, EPDM	6
	D10-092-2118	Tetra Seal, PTFE	6

*Non-metallic pump head

Torque and Threadlocker Requirements		
Ref. No.	Torque	Loctite® No.
41		242
46	18 in-lbs (2 N-m)†	242
51	45 ft-lbs (60 N-m)	242
52	45 ft-lbs (60 N-m)	
53		567

† Fluid end parts (44 - 46) are not used with PTFE diaphragms (43) part number D10-018-2348. Do not torque PTFE diaphragms (43), hand tighten only and apply Loctite 242.

D/G10 Hydraulic End Parts

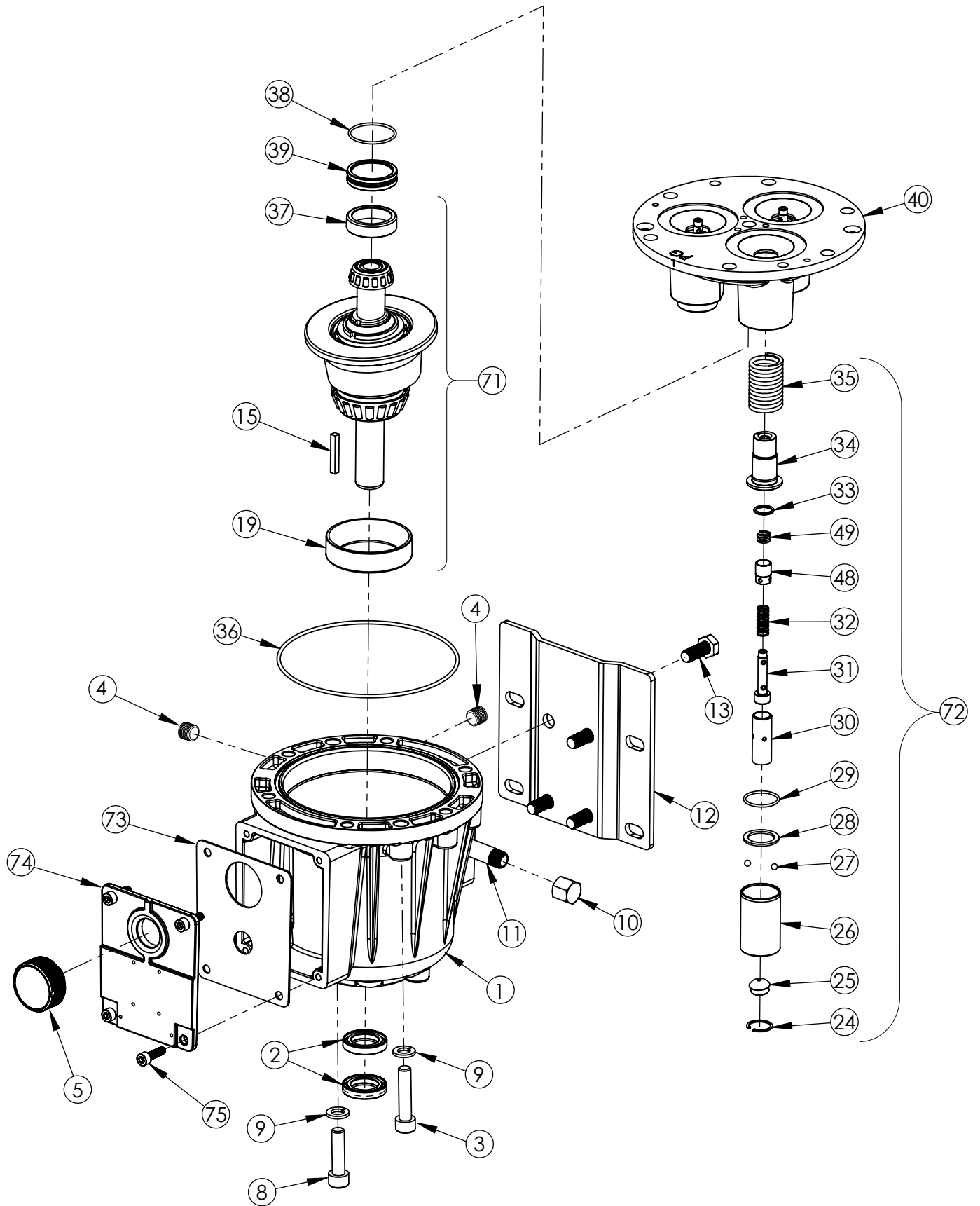

D/G10 Hydraulic End Parts

Ref. No.	Part Number	Description	Quantity/ Pump
1	G10-001-1150	Pump Housing ^{A1}	1
	G10-001-1250	Pump Housing Assembly ^{A2}	1
2	D10-031-2110	Seal , Buna-N.....	2
3	G10-087-2011	Screw, Cap, hex-hd, 45 mm	1
4	D10-076-2250	Plug, 1/4 in. NPT	2
5	D03-039-1030	Cap with O-ring, Oil fill	1
8	G10-089-2011	Screw, Cap, hex-hd, 38 mm.....	1
9	G25-048-2010	Washer, Split lock	8
10	D10-078-2250	Cap, Brass, 1/4 in.	1
11	D10-077-2250	Nipple, Brass, 1/4 x 2-1/2" long	1
12	D10-025-1010	Base plate	1
13	G10-029-2010	Screw, Cap, hex-head, 25 mm.....	4
15	D10-085-2210	Key, Shaft.....	1
19	D10-010-2911	Bearing Cup	3
24	D10-050-3010	Ring, retaining	3
25	D10-013-1010	Foot	3
26	D10-014-1010	Piston Body	3
27	D10-015-3010	Ball	6
28	D10-041-1010	Washer, Ball retainer.....	3
29	D10-034-2110	O-ring, Buna-N.....	3
30	K10-043-1020	Sleeve, spool valve.....	3
31	K10-044-1020	Spool, valve.....	3
32	K15-045-3111	Priming, spring	3
33	C23-009-2110	O-ring, Valve cylinder, Buna-N	3
34	K15-042-1010	Retainer, Spring	3
35	D10-019-3110	Spring, Piston return	3
36	D10-037-2110	O-ring,	1
37	D10-011-2911	Bearing Cup	1
38	D10-035-2110	O-ring,	1
39	D10-012-1010	Bearing Adjusting Plate.....	1
40	K10-002-1252	Cylinder Housing, Loaded, Hydra-Cell Pro, Neoprene ^{A3}	1
	K10-002-1253	Cylinder Housing, Loaded, Hydra-Cell Pro, EPDM ^{A3}	1
	K10-002-1254	Cylinder Housing, Loaded, Hydra-Cell Pro, BUNA ^{A3}	1
	K10-002-1255	Cylinder Housing, Loaded, Hydra-Cell Pro, FKM ^{A3}	1
	K10-002-1256	Cylinder Housing, Loaded, Hydra-Cell Pro, PTFE ^{A3}	1
	K10-002-1257	Cylinder Housing, Loaded, Hydra-Cell Pro, Aflas ^{A3}	1
	K10-002-1258	Cylinder Housing, Loaded, Hydra-Cell Pro, Butyl ^{A3}	1

Ref. No.	Part Number	Description	Quantity/ Pump
48	K15-150-1000	Bias spring spacer	3
49	K15-045-3110	Overfill spring	3
71	D10-007-1210	(X) Cam Assembly, 8 gpm @ 1450 rpm ^{A4}	1
	D10-007-1214	(E) Cam Assembly, 8 gpm @ 1750 rpm ^{A4}	1
72	K10-014-1220	Piston Assembly ^{A5}	3
73	G10-106-2350	Gasket, Cover	1
74	G10-105-1050	Cover.....	1
75	G03-088-2010	Screw, 20 mm.....	4

^{A1} Pump housing includes housing (1), gasket (73), cover (74), and screws (75).

^{A2} Pump Housing Assembly includes housing (1), oil drain/plugs (4, 10), gasket (73), cover (74), and screws (75).

^{A3} Loaded Cylinder Housing includes Fluid End parts (42 - 46) and Hydraulic End parts (24 - 35, 38, 39, 48, 49).

^{A4} Cam Assembly includes: cam, shaft, wobble plate, and bearings (15, 19, 37).

^{A5} Piston Assembly includes: piston, piston foot, retaining ring, and items (24 - 35, 48, 49).

Torque and Threadlocker Requirements		
Ref. No.	Torque	Loctite® No.
4		567
10		567
11		609
13	25 ft-lbs (35 N-m)	609

D/G10 Troubleshooting

Problem	Probable Cause	Solution
Motor/Pump Does Not Operate:	No power.	Supply correct power according to motor requirements.
	Blown fuse/tripped circuit breaker.	Replace/reset, eliminate circuit overload.
	Shaft coupling to pump not in place.	Install proper coupling hardware (see parts list).
	Current overload - motor.	Motor not rated for pump operating conditions - install proper motor.
	Thermal overload - motor.	Motor not rated for pump and/or ambient operating conditions - supply cooling or install proper motor.
	Faulty motor drive/controller.	Repair/replace.
	Faulty motor.	Repair/replace.
No Delivery:	Low liquid level in supply tank (if low-level shut-off is used).	Fill tank.
	Supply tank empty.	Fill tank.
	Loss of prime.	Reprime using Initial Start-Up Procedure.
	Inlet line or strainer clogged.	Clear debris and flush, or replace.
	Inadequate supply pressure at pump inlet.	Increase supply pressure by raising fluid level in tank, raising tank, or pressurizing suction tank.
	Inlet line too restrictive.	Increase inlet line diameter and/or decrease inlet line length.
	Fluid viscosity too high.	Reduce viscosity if possible (by heat or some other means). Increase inlet line diameter and/or decrease inlet line length. Increase supply pressure.
	Vapor lock/cavitation.	Increase inlet pressure. Decrease fluid temperature.
	Pump valves held open or worn out.	Clear debris and flush, or replace (see Fluid End Service)
Delivery Too Low and/or Erratic:	System relief valve actuating.	Adjust relief valve or repair, clean or replace with new relief valve.
	Review all Probable Causes and Solutions in Problem 2, No Delivery above.	
	Air leak(s) in inlet line.	Locate all leaks and repair.
	System back pressure too low.	Adjust back pressure valve to higher setting. Install back pressure valve if none in system.
	Pumped fluid characteristics changed.	Monitor supply tank temperature to determine if fluid is too hot (leading to cavitation) or too cold (increasing fluid viscosity). Stabilize temperature at suitable level to resolve problem. Check for entrapped air in the fluid supply system.
	Inlet supply pressure changed.	Monitor inlet supply pressure (at the pump) to determine if it is too low, causing a starved condition/cavitation. Stabilize pressure at suitable level to resolve problem.
Delivery Too High and/or Erratic:	Oil condition in pump hydraulic end changed.	Check oil level - if low, evaluate for source of leakage. Consult factory for hydraulic end service. Change oil per recommended guidelines in maintenance section.
	System back pressure too low.	Adjust back pressure valve to higher setting. Install back pressure valve if none in system.
Delivery Too High and/or Erratic:	Inlet supply pressure changed.	Monitor inlet supply pressure (at the pump) to determine if it is too high, causing a "flow-through" condition. Stabilize pressure at suitable level to resolve problem.

D/G10 Pump Motor Adapter Kits

Installation

- Fasten pump/motor adapter to pump using socket-head cap screws (2) with lock washers (3).
- Attach coupling hubs (not included in Adapter Kit), to pump and motor shafts. Slide coupling sleeve onto pump shaft coupling hub, then engage onto motor coupling hub.
- Assemble adapter to motor using hex-head cap screws (4) and lockwashers (5). IEC motors use additional lockwashers (5) and nuts (6).
- Make any adjustments to the position of the coupling hubs through the access slots in the sides of the adapter. Tighten coupling sleeve set screws.

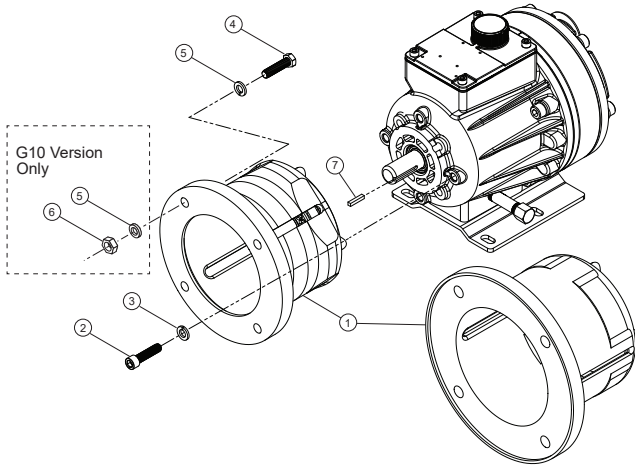

Ref No.	Description	A04-001-1200 ¹	A04-002-1200 ¹	Qty/Kit
		A04-003-1200 ²	A04-004-1200 ²	
1	Pump/Motor Adapter	A04-032-1050 ¹	A04-033-1050 ¹	1
		A04-032-1051 ²	A04-033-1051 ²	1
2	Screw, Cap, soc-hd	G10-089-2010	G10-089-2010	4
3	Lock washer, Split	G25-048-2011	G25-048-2011	4
4	Screw, Cap, hex-hd	D03-068-2010 ¹	M10-110-2000 ¹	4
		A04-046-2010 ²	A04-043-2010 ²	4
5	Lock washer, Split	D10-048-2010 ¹	M10-111-2000 ¹	4
		A04-044-2010 ²	M10-111-2000 ²	8
6	Nut, hex	A04-047-2010 ²	A04-045-2010 ²	4
7	Key, Short	A04-085-2210	A04-085-2210	1

¹ D10.

² G10.

Adapter: A04-001-1200; A04-003-1200

Adapter: A04-002-1200; A04-004-1200

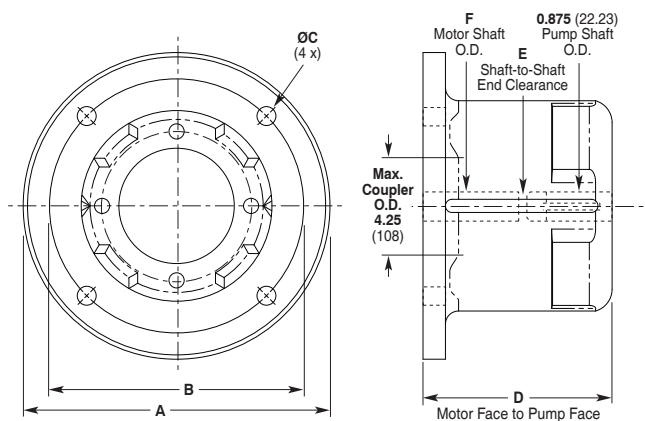
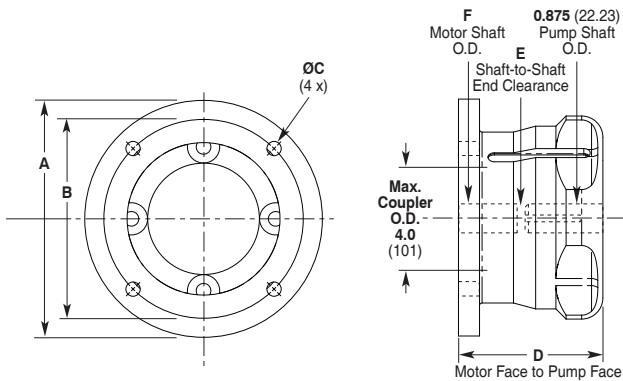

Dimensions in (mm)

Pump Model	Kit Part Number	Adapter Kit Motor Size	A	B	C	D	E	F
D10	A04-001-1200	NEMA 56C	7.00	5.875	0.42	4.25	0.76	0.625
		NEMA 143/145TC	7.00	5.875	0.42	4.25	0.70	0.875
	A04-002-1200	NEMA 182/184TC	8.75	7.25	0.54	5.30	1.12	1.125
		NEMA 213/215TC	8.75	7.25	0.54	5.30	0.37	1.375
G10	A04-003-1200	IEC 80 B5 Flange	---	(165)	(10.7)	(108)	(31.8)	(19)
		IEC 90 B5 Flange	---	(165)	(10.7)	(108)	(21.7)	(24)
	A04-004-1200	IEC 100-112 B5 Flange	(248)	(215)	(12.7)	(137)	(32.6)	(28)

D/G10 Wanner Tool Kit

The D/G10 Wanner Tool Kit (Part No. A03-175-1101) contains the tools illustrated below. These tools are used to assist in the repair and maintenance of the D10 and G10. See the Fluid End Service and Hydraulic End Service sections of this manual for specific application.

Note: Wanner strongly recommends the use of this tool kit when repairing or servicing the pump (available from Wanner or your local distributor).

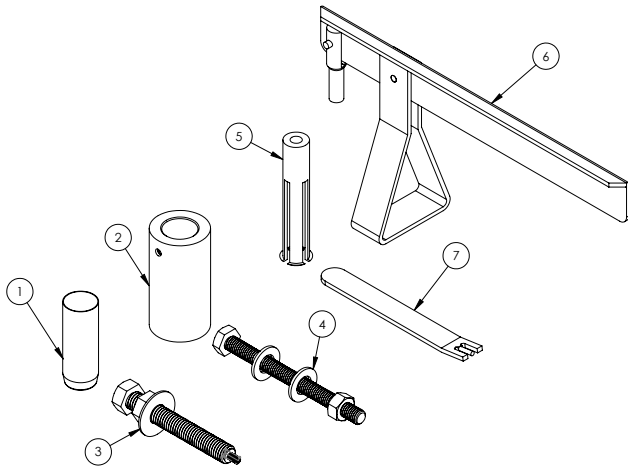

Ref. No.	Part No.	Description	Quantity/Kit
1	A03-157-1000	Seal, Protector.....	1
2	A03-159-1200	Inserter/Shaft Rotator.....	1
3	A03-162-1200	Plunger, Lifter.....	1
4	A03-156-1200	Assembly Studs.....	3
5	A03-118-1000	Seat Puller.....	1
6	A03-124-1200	Seat Puller, Lever Assembly.....	1
7	A03-125-1010	Plunger Holder.....	1

D/G10 Series Replacement Parts Kits

TO ORDER REPLACEMENT PARTS KIT: A Replacement Parts Kit contains 11 digits corresponding to customer-specified design options.

1	2	3	4	5	6	7	8	9	10	11
G	1	0		5						

Digit	Order Code	Description
1-3	G10	Pump Configuration For all D10 & G10 Pumps
4	K D V	Kit Designator Complete Fluid End Kit Diaphragm Kit Valve Kit (diaphragm not included)
5-6	52 55	Pump Version Metallic Pump Head Version Non-Metallic Pump Head Version
7	A B C E G J P T	Diaphragm & O-ring Material Aflas diaphragm / PTFE O-ring Butyl diaphragm / PTFE O-ring FFKM diaphragm / PTFE O-ring EPDM FKM PTFE Neoprene Buna-N
8	C D H S T X	Valve Seat Material Ceramic Tungsten Carbide 17-4 Stainless Steel 316L Stainless Steel Hastelloy® C Not included in Diaphragm Kit
9	C D F N T X	Valve Material Ceramic Tungsten Carbide 17-4 Stainless Steel Nitronic® 50 Hastelloy® C Not included in Diaphragm Kit
10	E T X	Valve Springs Elgiloy® Hastelloy® C Not included in Diaphragm Kit
11	C H M P T Y X	Valve Spring Retainers Celcon® 17-7 Stainless Steel (used with metallic heads only) PVDF Polypropylene Hastelloy® C (used with metallic heads only) Nylon Not included in Diaphragm Kit

Kit Contents			Kit Designator		
Part Number*	Description	Qty	K	D	V
D10-018-___	Diaphragm	3	•	•	
D10-047-___	O-ring, Follower	3	•	•	
D10-074-___	or				
D10-109-___	O-ring, Outer manifold ¹	1	•	•	•
D10-073-___	O-ring, Inner manifold	1	•	•	•
D10-083-___	O-ring, Center bolt	1	•	•	•
D10-035-___	O-ring, Valve seat	6	•		•
D10-020-___	Valve seat	6	•		•
D10-021-___	Valve	6	•		•
D10-022-___	Valve spring	6	•		•
D10-092-___	Tetra seal ²	6	•		•
D10-023-___	Retainer, Valve spring	6	•		•
D10-125-___	Washer, Dampening ³	6	•		•
A01-113-3400	Threadlocker	1	•	•	

* Last four digits of part numbers with ___ refer to specific material of construction.

¹D10-074 is provided for metallic heads; D10-109 is provided for non-metallic heads.

²Tetra Seal is provided with non-metallic spring retainers only.

³Dampening washer is provided for non-metallic heads only.

Hydra-Cell® is a registered trademark of Wanner Engineering, Inc.
Hydra-Cell Pro® is a registered trademark of Wanner Engineering, Inc.
Elgiloy® is a registered trademark of Elgiloy Limited Partnership
Hastelloy® C is a registered trademark of Haynes International, Inc.
Nitronic® 50 is a registered trademark of AK Steel Corporation
Celcon® is a registered trademark of the Celanese Corporation
Loctite® is a registered trademark of Henkel Corporation

D/G10 Warranty

Limited Warranty

Wanner Engineering, Inc. ("Wanner") extends to the original purchaser of equipment supplied or manufactured by Wanner and bearing its name, a limited one-year warranty from the date of purchase against defects in material or workmanship, under normal use and service, and provided the equipment is installed, operated and maintained in accordance with instructions supplied by Wanner. Wanner will repair or replace, at its option, defective parts without charge if: (a) you provide written notice of any defect within thirty (30) days from the discovery of the defect; (b) the claim is received by Wanner before the expiration of the warranty period; and (c) such parts are returned with transportation charges prepaid to Wanner Engineering, Inc., 1204 Chestnut Avenue, Minneapolis, Minnesota 55403. A return goods authorization must be received prior to the return of the defective part. No allowance will be made for repairs undertaken without Wanner written consent or approval.

Notwithstanding anything to the contrary, this warranty does not cover:

1. Electric motors (if applicable) not manufactured by Wanner. The warranties, if any, on such equipment are assigned to you by Wanner (without recourse) at the time of purchase.
2. Normal wear and/or damage caused by or related to abrasion, corrosion, abuse, negligence, accident, faulty installation or tampering which impairs normal operation.
3. Transportation costs.

This limited warranty is exclusive, and is in lieu of any other warranties (oral, express, implied or statutory) including, but not limited to, implied warranties of merchantability and fitness for a particular purpose; warranties of non-infringement; warranties arising from course of dealing or usage of trade or any other matter. Any descriptions of the equipment, drawings, specifications, and any samples, models, bulletins, or similar material used in connection with the sale of equipment are for the sole purpose of identifying the equipment and are not to be construed as an express warranty that the equipment will conform to such description. Any field advisory or installation support is advisory only. Every form of liability for direct, special, incidental or consequential damages or loss is expressly excluded and denied. All liability of Wanner shall terminate one (1) year from the date of purchase of the equipment.